

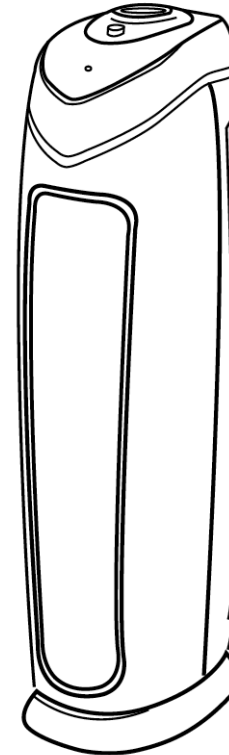

## USE & CARE INSTRUCTIONS



### Refurbished Air Cleaning System

**Model No. RAC4825/RAC5000/RAC5110CS**

30 -Day Limited Warranty

[www.guardiantechnologies.com](http://www.guardiantechnologies.com) • 1.866.603.5900

REV1115



**Guardian Technologies LLC**

26251 Bluestone Blvd. | Euclid, Ohio 44132  
1.866.603.5900 | [www.guardiantechnologies.com](http://www.guardiantechnologies.com)

©2015 Guardian Technologies LLC

**Replacement Filter/RAC4825 22" Model: Filter **B** (FLT4825)**  
**Replacement Filter/RAC5000/RAC5110CS 28" Model: **C** (FLT5000)**  
To order Contact Customer Service  
**1.866.603.5900 or log on to [www.guardiantechnologies.com](http://www.guardiantechnologies.com)**

## READ AND SAVE THESE INSTRUCTIONS WARNINGS

Failure to comply with the warnings listed below may result in electric shock or serious injury.



This product should be used only in accordance with the specifications outlined in this manual. Usage other than what has been specified here may result in serious injury.

**WARNING: THE CORDS, WIRES AND/OR CABLES SUPPLIED WITH THIS PRODUCT CONTAIN CHEMICALS, INCLUDING LEAD OR LEAD COMPOUNDS, KNOWN TO THE STATE OF CALIFORNIA TO CAUSE CANCER AND BIRTH DEFECTS OR OTHER REPRODUCTIVE HARM. WASH HANDS AFTER USING. (CALIFORNIA CODE OF REGULATIONS PROPOSITION 65)**

When using electrical appliances, basic precautions should always be followed to reduce the risk of fire, electric shock and injury to persons, including the following:

- Read all instructions before using appliance.
- **IMPORTANT** - This appliance has a polarized plug (one blade is wider than the other). To reduce the risk of electric shock, this plug is intended to fit in a polarized outlet only one way. If the plug does not fit fully in the outlet, reverse the plug. If it still does not fit, contact a qualified electrician. Do not attempt to defeat this safety feature.
- To avoid fire or shock hazard, plug the appliance directly into a 120V AC electrical outlet.
- Keep the cord out of heavy traffic areas. To avoid fire hazard, NEVER put the cord under rugs, near heat registers, radiator, stoves or heaters.
- To protect against electrical hazards, DO NOT immerse in water or other liquids. Do not use near water.
- Children cannot recognize the hazards associated with the usage of electrical appliances. For this reason, always supervise children when they are near the unit.
- Always unplug the air purifier before moving it, opening the grill, changing filters, cleaning or whenever the air purifier is not in use. Be sure to pull by the plug and not the cord.
- NEVER drop or insert any object into any openings.
- DO NOT run cord under carpeting.
- DO NOT cover cord with throw rugs, runners, or similar coverings.
- DO NOT route cord under furniture or appliances. Arrange cord away from traffic area and where it will not be tripped over.
- DO NOT operate any appliance with a damaged cord or plug, if motor fan fails to rotate, after the appliance malfunctions, or if it has been dropped or damaged in any manner. Call Customer Service at **1.866.603.5900** for assistance.
- Use appliance only for intended household use as described in this manual. Any other use not recommended by the manufacturer may cause fire, electric shock or injury to persons.
- DO NOT use outdoors.
- DO NOT place anything on top of unit.

## READ AND SAVE THESE INSTRUCTIONS WARNINGS

Failure to comply with the warnings listed below may result in electric shock or serious injury.

- NEVER block the air openings, grills/outlets or place on a soft surface such as a bed or sofa, as this could cause the unit to tip over, blocking the air intake or outtake opening.
- DO NOT attempt to repair or adjust any electrical or mechanical functions on this unit. Doing so will void your warranty. The inside of the unit contains no user serviceable parts. All servicing should be performed by qualified personnel only.
- **WARNING:** To reduce the risk of fire or electric shock, do not use this fan with any solid-state speed control device.



**LAMP CONTAINS MERCURY**



**Manage in accordance with Spills, Disposal and Site Cleanup Requirements. In case of breakage, follow clean-up procedures provided by contacts below.**

[www.epa.gov/cficleanup](http://www.epa.gov/cficleanup)  
**1-866-284-4010**

## PRODUCT SPECIFICATIONS

**MODEL NUMBER SERIES:** RAC4825  
**DIMENSIONS:** 10.25" L x 6.75" W x 21.5" H  
**WEIGHT:** 8.65 pounds  
**INPUT VOLTAGE:** 120 V, 60Hz, 55W, 0.5 Amps  
**REPLACEMENT FILTER:** Filter B (FLT4825)  
**REPLACEMENT BULB:** LB4000  
**BULB:** 4W  
**WARRANTY:** 30-Day Limited Warranty

**MODEL NUMBER SERIES:** RAC5000/RAC5110CS  
**DIMENSIONS:** 11" L x 6.75" W x 27.25" H  
**WEIGHT:** 10.95 pounds  
**INPUT VOLTAGE:** 120 V, 60Hz, 60W, 0.5 Amps  
**REPLACEMENT FILTER:** Filter C (FLT5000)  
**REPLACEMENT BULB:** LB5000  
**BULB:** 8W  
**WARRANTY:** 30-Day Limited Warranty

## PRODUCT PARTS

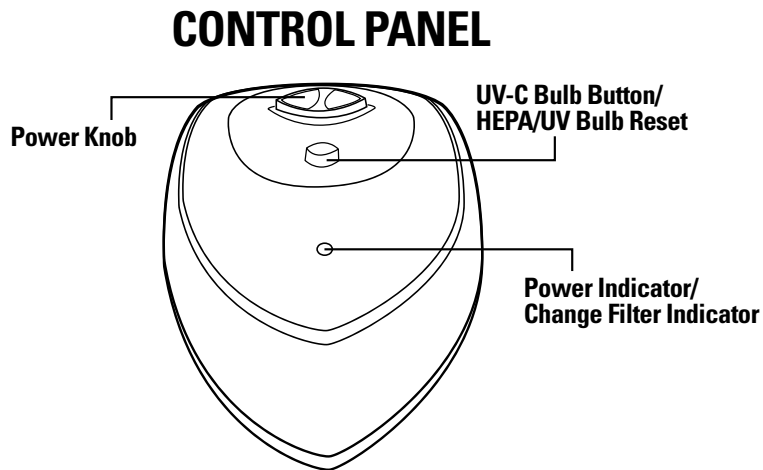
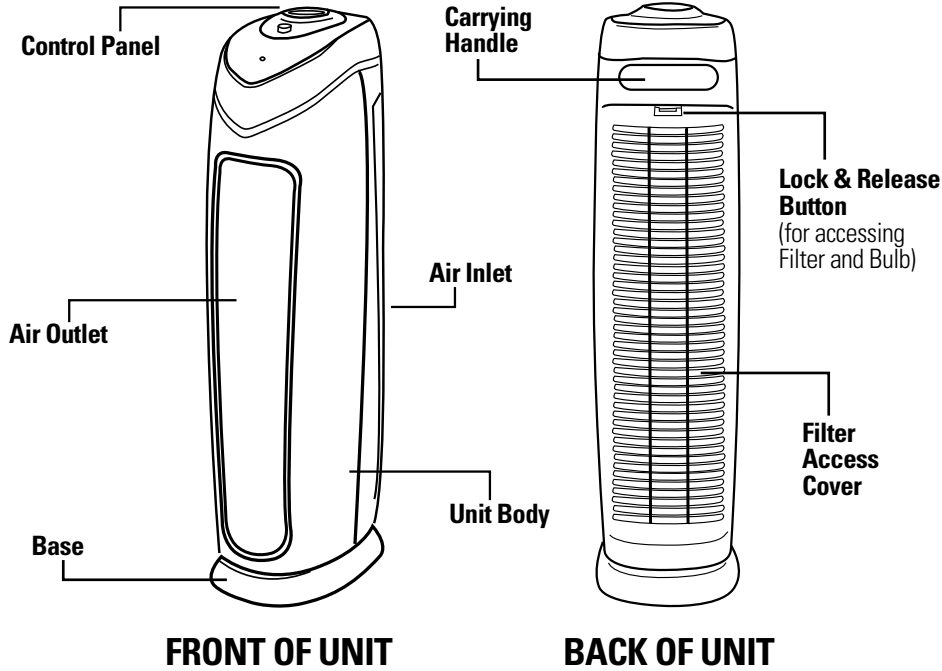

## AIR CLEANING SYSTEM

Improve your indoor air quality with your new Germ Guardian® Air Cleaning System. Multiple levels of cleaning include a combination True HEPA filter that captures allergens, and Charcoal filter to remove odors. UV-C light technology enhances germ-killing.

### PRE-FILTER\*

Captures initial dust and allergen particles.

### CHARCOAL FILTER\*

Contributes to the control and prevention of the growth of bacteria, germs and mold.

### TRUE HEPA FILTER

Captures 99.99% of dust and allergens.

### UV-C LIGHT

UV-C light technology works with filters to enhance the elimination of airborne germs. Titanium Dioxide is activated by the UV-C light to decompose remaining odor molecules caused by smoking, cooking and pets.

\*Pre-Filter and Charcoal Filter are combined into one layer that attaches to the HEPA Filter.

## AIR CLEANING LAYERS

### AC4825 SERIES

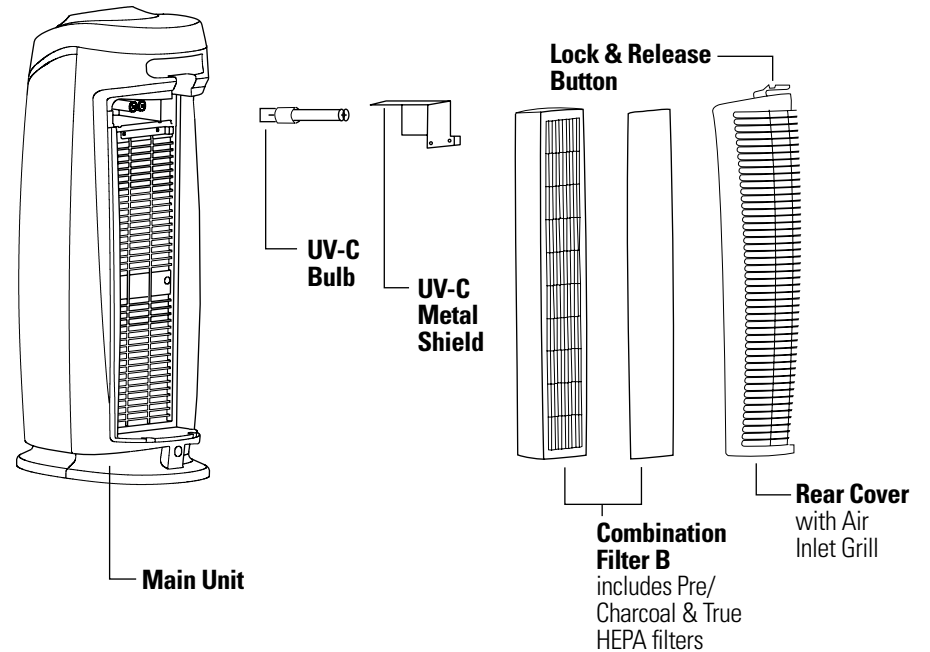

## AIR CLEANING LAYERS

### AC5000 SERIES

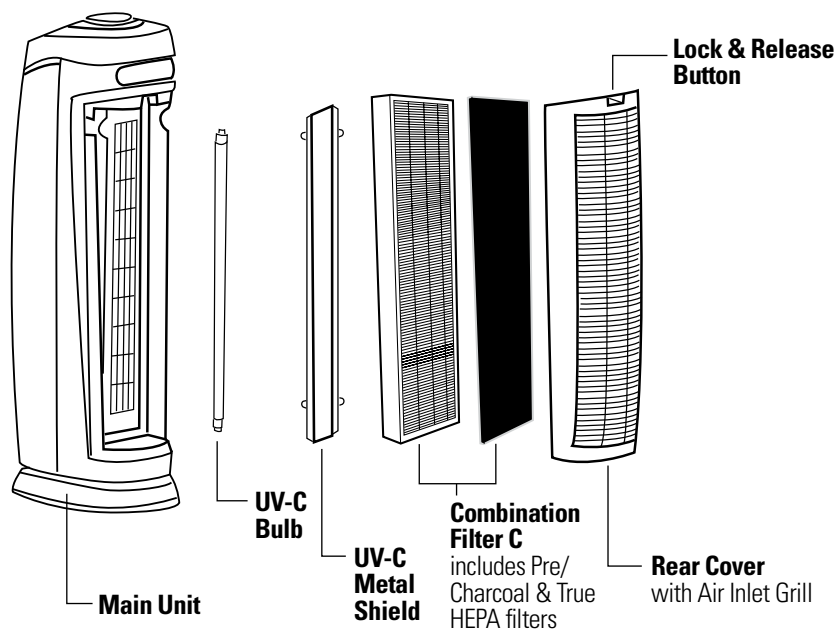

## OPERATING INSTRUCTIONS

### BEFORE OPERATING THE AIR PURIFIER:

- Carefully remove your air purifier from box and bag.
- Select a firm, level and flat location for the air purifier.
  - \* For proper air flow, locate the unit at least 1 foot from any wall or furniture.
  - \* Make sure none of the grills are blocked.

- Plug the power cord into a 120V AC outlet.

**IMPORTANT:** When moving the air purifier, always lift unit by the carrying handle located on back.

### OPERATING THE AIR PURIFIER:

- Turn the air purifier ON by rotating POWER KNOB clockwise.
- Upon turning the air purifier ON, the power indicator will be lit (green) and the unit will be in LOW mode (🌀).
- Rotate the POWER KNOB clockwise to set the air purifier to MEDIUM (🌀) or High mode (🌀).
- To activate the UV-C Bulb, press the UV button. Press the button again to turn OFF the UV-C Bulb.
- To turn the unit OFF, rotate the POWER KNOB counter-clockwise to OFF mode (●).

## INSTALLING & REMOVING COMBINATION FILTER

### CHANGE FILTER INDICATOR

The green power light on the air cleaner will turn red and flash continuously indicating that it is time to replace the filter. Replace the filter according to the directions then press the UV control button and hold for 5 seconds to restart the system. The light will turn back to green. Depending on usage, filter will last approximately 6 months.

### REPLACE FILTER

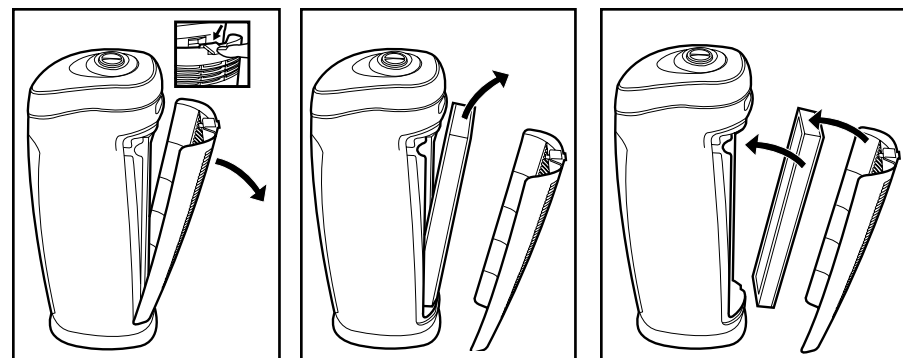

- Turn off and unplug the unit.
- Press the Lock & Release Button and remove the Rear Cover from the unit.
- Remove the used Combination Filter.
- Insert new Combination Filter into the unit. Consult the arrow on the filter for correct installation direction.
- Reattach the Rear Cover of the unit and securely latch into place.
- Push and hold UV Control Button for 5 seconds to reset Filter Change Indicator.



**Check out our on-line Filter Reminder and Replacement program.**

[www.guardiantechnologies.com](http://www.guardiantechnologies.com)

# CLEANING & MAINTAINING THE COMBINATION FILTER

The air purifier should be cleaned at least once every month and the outer Pre-/Charcoal Filter attached to the HEPA Filter should be cleaned every month. More frequent cleaning may be required depending on environmental conditions.

## PRE-/CHARCOAL FILTER

Clean with the brush attachment of your vacuum cleaner. This will remove lint and dirt.

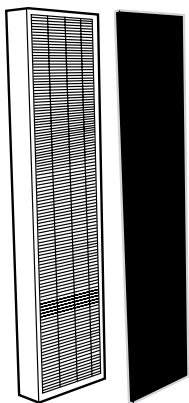

Filter Package includes:

- 1-Piece True HEPA Filter
- 1-Piece Pre-/Charcoal Filter

Filter lasts approximately 6-8 months depending on use

Create **ONE COMPLETE COMBINATION FILTER**

## TRUE HEPA FILTER

Remove the Combination Filter from the back of unit.

Remove the Pre-/Charcoal Filter to expose the HEPA filter.

When the HEPA Filter turns from white to grey or black it should be replaced with a new one. If the HEPA filter is still white, it does NOT need to be replaced.

**IMPORTANT:** Do NOT try to wash and re-use the Combination Filter. Please contact Customer Service at **1.866.603.5900** or visit us at **www.guardiantechnologies.com** to purchase a replacement filter.

<b>AC4825 Series Replacement Filter</b>	<b>FILTER B (FLT4825)</b>
<b>AC5000 Series Replacement Filter</b>	<b>FILTER C (FLT5000)</b>

**NOTE:** The Combination Filter is one filter system. The multiple layers include: the Pre-/Charcoal Filter and the True HEPA Filter.

## AIR PURIFIER

Use a clean, dry, soft cloth to wipe the external surface of the unit.

## AC4825 SERIES

### Clean Air Delivery Rate

From air cleaner to air cleaner, compare the CADR numbers. First look at suggested room size. Then refer to the Clean Air Delivery Rate (CADR) numbers. The higher the number, the faster the unit filters the air.

**This air cleaner is suggested for use in a single, closed room up to 155 square feet.**

Higher CADR rates provide improved performance in all room sizes. Portable air cleaners will be much more effective in rooms when all the doors and windows are closed.

### TOBACCO SMOKE: 100+ AC4825

This value represents performance that can be expected within the first 72 hours of operation. Subsequent use may vary with use.

Tested per ANSI/AHAM AC-1 National Standard

## AC5000 SERIES

### Clean Air Delivery Rate

From air cleaner to air cleaner, compare the CADR numbers. First look at suggested room size. Then refer to the Clean Air Delivery Rate (CADR) numbers. The higher the number, the faster the unit filters the air.

**This air cleaner is suggested for use in a single, closed room up to 193 square feet.**

Higher CADR rates provide improved performance in all room sizes. Portable air cleaners will be much more effective in rooms when all the doors and windows are closed.

### TOBACCO SMOKE: 125+ AC5000

This value represents performance that can be expected within the first 72 hours of operation. Subsequent use may vary with use.

Tested per ANSI/AHAM AC-1 National Standard

## What is CADR?

CADR stands for "Clean Air Delivery Rate," which indicates the volume of filtered air delivered by an air purifier. CADR ratings show the effectiveness of how efficient the air purifier is at capturing fine particulates from things like tobacco smoke and plant pollens from the room.

**NOTE:** Do NOT stick any foreign objects or your fingers inside of the unit.

**CAUTION:** Do NOT use gasoline, benzene, thinner, harsh cleaners, etc. on and/or in the unit while cleaning as they will damage the product.

**NEVER** use alcohol or other solvents.

# INSTALLING & REMOVING UV-C BULB

## CHANGE BULB INDICATOR

The blue light on the front of air cleaner will begin to flash continuously when it is time to replace the UV-C bulb. Replace the bulb according to the directions then press the UV control button and hold for 5 seconds to restart the system. The light should remain a constant blue.

## REPLACE BULB

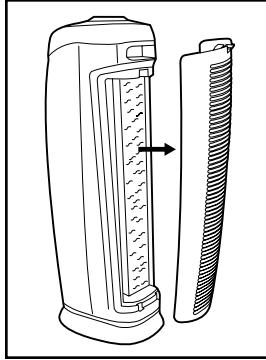

1. Remove the Rear Cover of the unit by pushing Lock & Release Button.

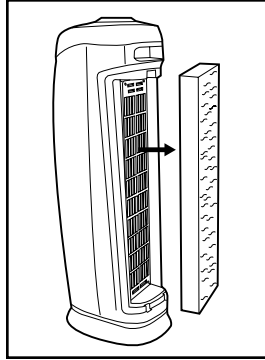

2. After removing the Rear Cover from the unit, remove the Combination Filter.

Continue reading below for remaining instructions on how to Install & Remove the UV-C Bulb for the AC4825 Series and the AC5000 Series.

## AC4825 SERIES

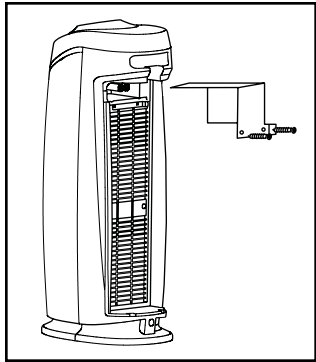

3. After removing the Combination Filter, use a Philips head screwdriver to remove two (2) screws and detach the UV-C Metal Shield.

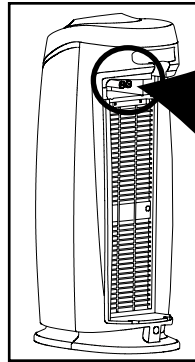

4. The UV-C Bulb is removed by carefully grasping the bulb with a clean cloth or tissue and pulling the bulb straight out of the unit.

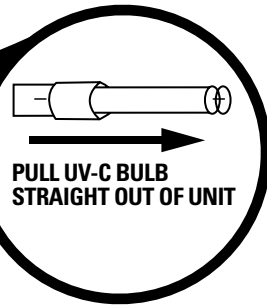

Bulb is NOT visible until the UV-C METAL SHIELD has been removed.

5. The UV-C Bulb is reinstalled by sliding it, horizontally, back into the slots at the top of the unit.  
6. Push and hold UV Control Button for 5 seconds to reset UV Bulb Change Indicator.

## REPLACEMENT BULB: LB4000

AVAILABLE AT 866.603.5900 OR WWW.GUARDIANTECHNOLOGIES.COM

# INSTALLING & REMOVING UV-C BULB

## AC5000 SERIES

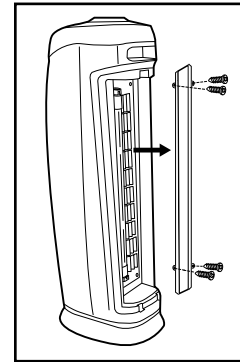

3. After removing the Combination Filter, use a Philips head screwdriver to remove four (4) screws and detach the UV-C Metal Shield.

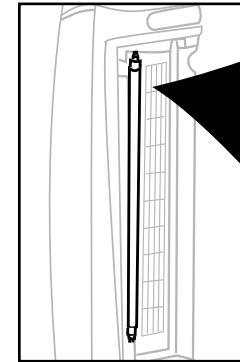

4. The UV-C Bulb is removed by carefully grasping the bulb with a clean cloth or tissue and twisting the bulb 1/4 turn. Remove from unit.

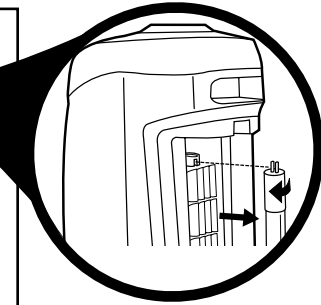

**TWIST BULB 1/4 TURN TO REMOVE BULB**

**Bulb is NOT visible until the UV-C METAL SHIELD has been removed.**

5. The UV-C Bulb is reinstalled by reversing the process in Step 4.  
6. Push and hold UV Control Button for 5 seconds to reset UV Bulb Change Indicator.

## REPLACEMENT BULB: LB5000

AVAILABLE AT 866.603.5900 OR WWW.GUARDIANTECHNOLOGIES.COM

**IMPORTANT:** The UV-C Bulb should be replaced every 10 - 12 months depending on use. Please contact Customer Service at **1.866.603.5900** or visit us at **www.guardiantechnologies.com** to purchase a replacement bulb.

# TROUBLESHOOTING GUIDE

PROBLEM	SOLUTION
Unit does not operate.	Check that the unit is plugged in. Call Customer Service <b>1.866.603.5900</b> .
Unit shuts off unexpectedly.	Check that the unit is plugged into a working electrical outlet. Check that the HEPA Filter is firmly in place. Check that the Rear Cover is latched firmly in place. Call Customer Service <b>1.866.603.5900</b> .
No air circulating from unit.	Unplug unit. Check Pre-/Charcoal and HEPA Filters. Clean Pre-/Charcoal Filter if necessary. Replace HEPA Filter if necessary.
Increase in noise level.	Make sure the filters are clean. Replace if necessary.
Power light is red and flashing.	Replace filter and reset system. See E-7.
Blue UV-C light is flashing.	Replace bulb and reset. See E-10, E-11.

# REPLACEMENT PARTS

To Purchase Contact Customer Service at  
**1.866.603.5900** or visit [www.guardiantechnologies.com](http://www.guardiantechnologies.com)

## AC4825 SERIES



FILTER B or FILTER B PET Replacement Filter  
Model No. **FLT4825**



Replacement UV-C Bulb  
Model No. **LB4000**

## AC5000 SERIES



FILTER C or FILTER C PET Replacement Filter  
Model No. **FLT5000**



Replacement UV-C Bulb  
Model No. **LB5000**

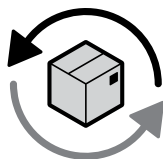

# AutoShip

Check out our on-line Filter Reminder  
and Replacement program.

[www.guardiantechnologies.com](http://www.guardiantechnologies.com)

# LIMITED WARRANTY

To the consumer, Guardian Technologies LLC warrants this product to be free of defects in materials or workmanship commencing upon the date of the original purchase. Save your original sales receipt to validate start of warranty period. Warranty is not valid without receipt.

If this product should become defective within the warranty period, we will repair or replace any defective parts free of charge. All warranty repairs must be completed by Guardian Technologies LLC. This warranty **does not cover unauthorized repairs**. The warranty does not include unusual wear, damage resulting from accident, or unreasonable use of the product. This warranty only covers the product when used with genuine Guardian Technologies accessories. This warranty covers product that was purchased from authorized distributors. This warranty gives you specific legal rights and you may also have other rights (other rights may vary from state to state in the U.S.A.)

**The product warranty registration can be completed online at [www.guardiantechnologies.com](http://www.guardiantechnologies.com).** We consider the registration process important to ensuring superior service to our customers, however submitting the warranty registration is optional and does not affect your rights to utilize this warranty according to the conditions stated above. To submit product under warranty the complete machine must be delivered pre-paid to Guardian Technologies LLC. Please include complete information including: the problem, the model number of the product, the day of purchase, and a copy of the original sales receipt along with your name, address, and telephone (email optional). Address returns to the attention of: Customer Service, at the address below. Additional questions or comments can be made toll free to the number listed below.

**Guardian Technologies LLC**  
26251 Bluestone Blvd.  
Euclid, Ohio 44132  
1.866.603.5900

[www.guardiantechnologies.com](http://www.guardiantechnologies.com)

This warranty can be registered online at [www.guardiantechnologies.com](http://www.guardiantechnologies.com).

Additional copies of the instruction manual can be obtained by accessing and printing directly from our website or calling customer service.